





The original language of this manual is English.

**Product Safety Information:**

Intended Use:

This pneumatic grinder is to be used only for removing material by utilizing appropriate abrasive wheels, rotary files or other material removal cutting devices.

For additional product safety information refer to Apex Tool Group, LLC or Apex Tool Group GmbH & Co. OHG document GS-2007, General Safety Pneumatic Grinders.



The grinder must not be modified in any manner unless approved in writing by Apex Tool Group, LLC or Apex Tool Group GmbH & Co. OHG. All safety devices must be properly installed and maintained in good working order.

**EC Declaration of Conformity:**

We affirm that this machine is in accordance with the following EC regulations (2006/42/EC). Applied harmonized standards are ISO 12100:2010-11.

The name, job function and address of the person authorized to compile the technical file.

Mr. Vishnu Irigreddy  
Director of Global R&D- Mechanical Engineering  
Apex Tool Group  
670 Industrial Drive  
Lexington, SC 29072

Signature: Vishnu Irigreddy  
Date: May 19, 2015

**Noise and Vibration:**

10L4321 Series Noise Level:

10L4321 Series Vibration Level:

**Air Line Lubrication:**

Use Apex Tool Group, LLC or Apex Tool Group GmbH & Co. OHG's lightweight air tool oil 500021 (available in quantities shown in the following chart) or an SAE-5 lightweight spindle oil.

Part No.	Packaged	Designation
540397	1 Quart (0.94 liter)	Airlube 10W/NR-420LB DR
533485	1 US Gallon (3.78 liter)	Airlube 10W/NR-420LB DR

**Air Supply Line:**

Parameter	Description
Air Hose	Minimum inside diameter: 1/2" (12.7mm) Maximum length: 8.0' (2.4 m)
Working pressure range	Performance rated at: 90 psi (620 kPa)
Compressed air	Air quality according to ISO 8573-1, quality class 2.4.3 The compressed air must be clean and dry.

**Service and Repair:**

Tool service and repair should be performed by an authorized Apex Tool Group, LLC or Apex Tool Group GmbH & Co. OHG Center. Refer to the last page of this manual for locations.



The governor module is factory sealed and cannot be repaired under any circumstances. User repair of the governor module must never be attempted. Replace with a new governor module of the same rated speed to prevent dangerous over speeding of the grinder.

**Disposal:**



Observe local disposal guidelines for all components of this tool and its packaging.

**Copyright Protection:**

Apex Tool Group, LLC or Apex Tool Group GmbH & Co. OHG reserves the right to modify, supplement or improve this document or the product without prior notice. This document may not be reproduced in any way, shape or form, in full or parts thereof, or copied to another natural or machine readable language or to a data carrier, whether electronic, mechanical, optical or otherwise without the express permission of Apex Tool Group, LLC or Apex Tool Group GmbH & Co. OHG

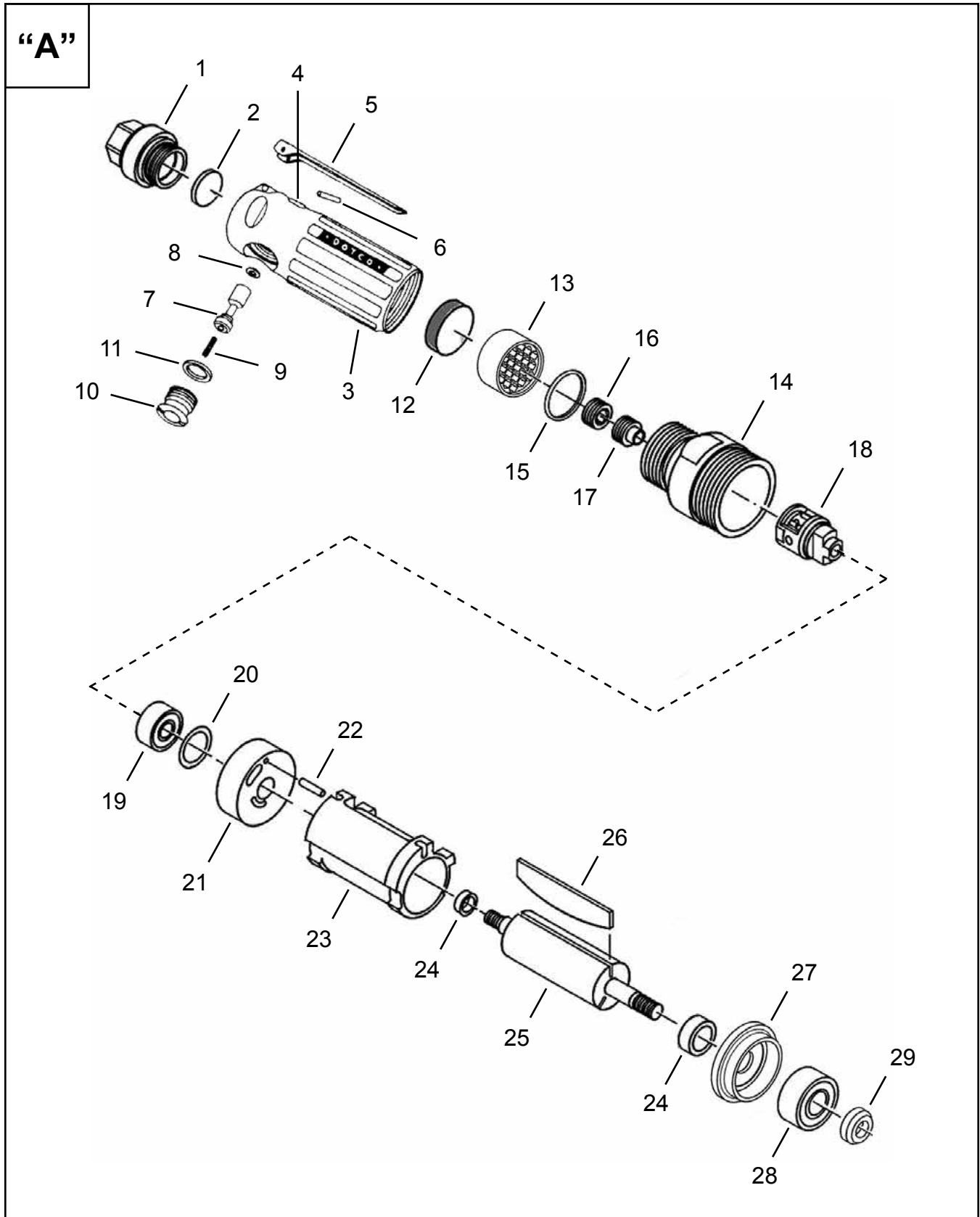

**Dotco®**  
Motor Assembly

**PL30-2040EN**  
05/19/2015

**Illustration "A"**

Ref	Number	#	X	EN
				Description
1	02-4083	1		Inlet Adapter (1/2" NPT) (includes Ref. 2)
2	4012PT	1	3	Air Inlet Screen
3	3281PT	1		Motor Housing (includes Ref. 4)
4	3279S *	1		Valve Bushing
5	1019PT	1	2	Throttle Lever
6	1042	1	2	Throttle Lever Pin
7	3282PT	1		Valve Stem (includes Ref. 8)
8	1056PT	1	3	O-Ring
9	2015PT	1	3	Valve Spring
10	02-3106	1		Plug Assembly (includes Ref. 11)
11	1189PT	1	3	O-Ring
12	4293	1	3	Filter Disc
13	02-5316	1		Filter Retainer
14	4181	1		Governor Housing (includes Ref. 15-17)
15	3036PT	1	3	O-Ring
16	3263PT	1		Nozzle Locknut
17	3262PT	1		Nozzle
18	4193S	1		Governor Module (12,000 RPM)
19	500PT	1	2	Ball Bearing
20	2488PT	1		Shim Packet
21	4168	1		Rear Bearing Plate (includes Ref. 22)
22	3062	1	2	Locating Pin
23	4189	1		Cylinder
24	2017PT	2	4	Rotor Spacer
25	4170S	1		Rotor
26	4171	3	9	Rotor Blade
27	4172	1		Front Bearing Plate
28	535	1	2	Ball Bearing
29	4239PT	1		Flange Hub

(#) Quantity

(X) Recommended Spare Parts (quantity shown based on 1-5 tools in operation)

\* Note: If necessary to replace the valve bushing, press the bushing, beveled end first, into the threaded end of the crosshole of the motor housing. The valve bushing base should be .562" plus .005" from the counterbored shoulder of the crosshole. Hone the inside diameter of the valve bushing to .2509" plus .0003".

**“B”**

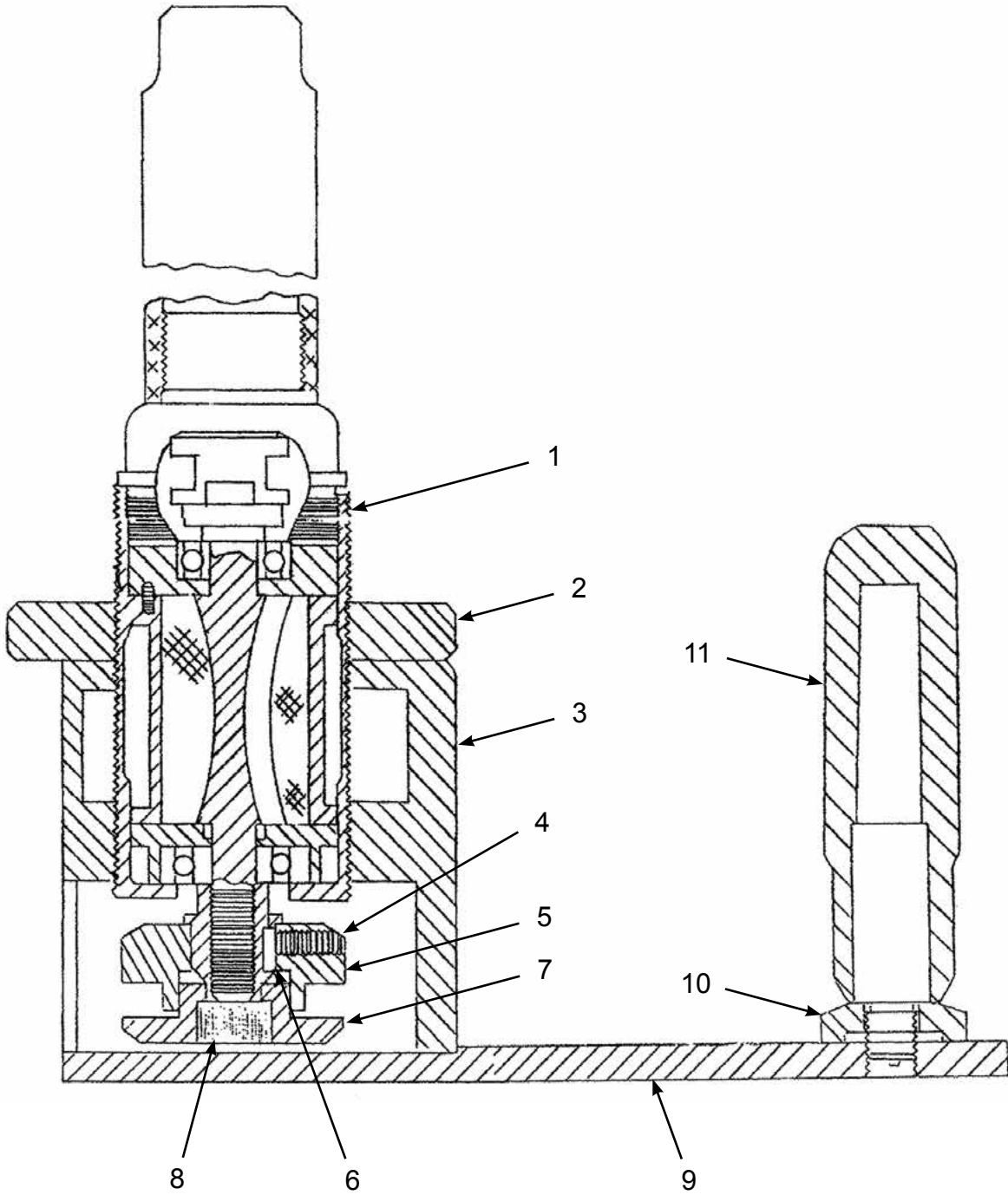

**Dotco®**  
Router Base Assembly

**PL30-2040EN**  
05/19/2015

**Illustration "B"**

Ref	Number	#	X	EN
				Description
1	4367PT	1		Motor Housing
2	4240PT	1		Adjusting Ring
3	4368PT	1		Base Housing
4	4047PT	1	2	Set Screw
5	4243PT	1		Top Flange
6	4057	1	3	Key
7	4242PT	1		Bottom Flange
8	4247PT	1	2	Cap Screw
9	4236PT	1		Base Plate
10	14-4072	1		Handle Flange
11	7678	1		Handle

(#) Quantity

(X) Recommended Spare Parts (quantity shown based on 1-5 tools in operation)

# POWER TOOLS SALES & SERVICE CENTERS

Please note that all locations may not service all products.

Contact the nearest Apex Tool Group Sales & Service Center for the appropriate facility to handle your service requirements.

## NORTH AMERICA | SOUTH AMERICA

### Detroit, Michigan

Apex Tool Group  
2630 Superior Court  
Auburn Hills, MI 48236  
Phone: +1 (248) 393-5640  
Fax: +1 (248) 391-6295

### Lexington, South Carolina

Apex Tool Group  
670 Industrial Drive  
Lexington, SC 29072  
Phone: +1 (800) 845-5629  
Phone: +1 (919) 387-0099  
Fax: +1 (803) 358-7681

### Louisville, Kentucky

Apex Tool Group  
1000 Glengarry Drive  
Suite 150  
Fairdale, KY 40118  
Phone: +1 (502) 708-3400  
[apexpowertools.com/service](http://apexpowertools.com/service)

### Canada

Apex Tool Canada, Ltd.  
7631 Bath Road  
Mississauga, Ontario L4T 3T1  
Canada  
Phone: (866) 691-6212  
Fax: (905) 673-4400

### Mexico

Apex Tool Group  
Manufacturing México  
S. de R.L. de C.V.  
Vialidad El Pueblito #103  
Parque Industrial Querétaro  
Querétaro, QRO 76220  
Mexico  
Phone: +52 (442) 211 3800  
Fax: +52 (800) 685 5560

### Brazil

Apex Tool Group  
Ind. Com. Ferram, Ltda.  
Av. Liberdade, 4055  
Zona Industrial Iporanga  
Sorocaba, São Paulo  
CEP# 18087-170  
Brazil  
Phone: +55 15 3238 3820  
Fax: +55 15 3238 3938

## EUROPE | MIDDLE EAST | AFRICA

### England

Apex Tool Group  
GmbH & Co. OHG  
C/O Spline Gauges  
Piccadilly, Tamworth  
Staffordshire B78 2ER  
United Kingdom  
Phone: +44 1827 8727 71  
Fax: +44 1827 8741 28

### France

Apex Tool Group S.A.S.  
25 rue Maurice Chevalier  
B.P. 28  
77831 Ozoir-La-Ferrière  
Cedex, France  
Phone: +33 1 64 43 22 00  
Fax: +33 1 64 43 17 17

### Germany

Apex Tool Group  
GmbH & Co. OHG  
Industriestraße 1  
73463 Westhausen  
Germany  
Phone: +49 (0) 73 63 81 0  
Fax: +49 (0) 73 63 81 222

### Hungary

Apex Tool Group  
Hungária Kft.  
Platánfa u. 2  
9027 Győr  
Hungary  
Phone: +36 96 66 1383  
Fax: +36 96 66 1135

## ASIA PACIFIC

### Australia

Apex Tool Group  
519 Nurigong Street, Albury  
NSW 2640  
Australia  
Phone: +61 2 6058 0300

### China

Apex Power Tool Trading  
(Shanghai) Co., Ltd  
Building A8, No. 38  
Dongsheng Road  
Pudong, Shanghai  
China 201201  
Phone: +86 21 60880320  
Fax: +86 21 60880298

### India

Apex Power Tools India  
Private Limited  
Gala No. 1, Plot No. 5  
S. No. 234, 235 & 245  
Indialand Global  
Industrial Park  
Taluka-Mulsi, Phase I  
Hinjawadi, Pune 411057  
Maharashtra, India  
Phone: +91 020 66761111

### Japan

Apex Tool Group Japan  
Korin-Kaikan 5F,  
3-6-23 Shibakoen, Minato-Ku,  
Tokyo 105-0011, JAPAN  
Phone: +81-3-6450-1840  
Fax: +81-3-6450-1841

### Korea

Apex Tool Group Korea  
#1503, Hibrand Living Bldg.,  
215 Yangjae-dong,  
Seocho-gu, Seoul 137-924,  
Korea  
Phone: +82-2-2155-0250  
Fax: +82-2-2155-0252

### Apex Tool Group, LLC

1000 Lufkin Road  
Apex, NC 27539  
Phone: +1 (919) 387-0099  
Fax: +1 (919) 387-2614  
[www.apexpowertools.com](http://www.apexpowertools.com)

# DOTCO®